

WZIFLOW CONTROL

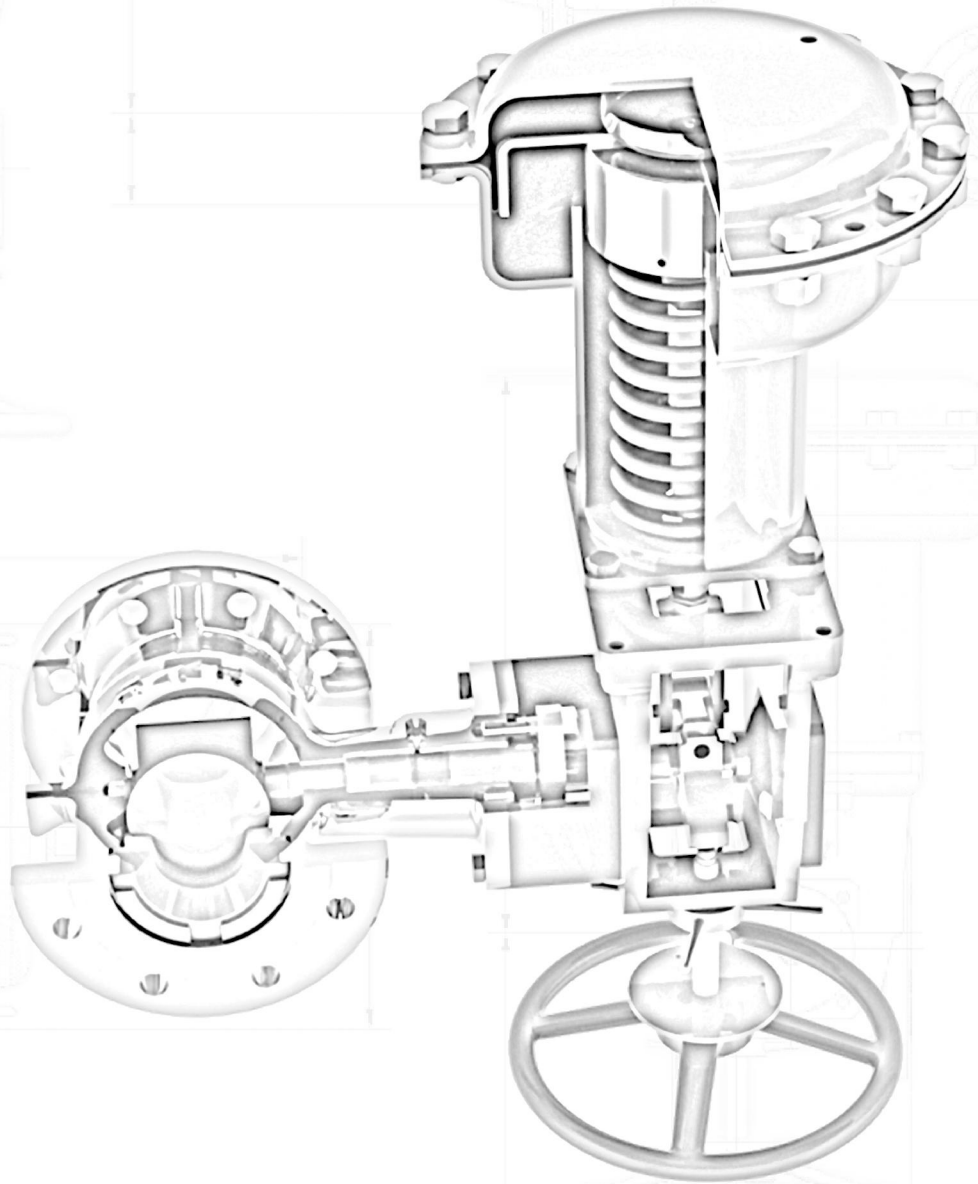

SERIES VFR

ROTARY ECCENTRIC PLUG CONTROL VALVE

TABLE OF CONTENTS

PRODUCT FEATURES..... VFR 2
 ROTARY ECCENTRIC PLUG VALVE..... VFR 3
 FLOW CHARACTERISTICS..... VFR 4-5
 DIMENSIONS AND WEIGHTS..... VFR 6-9
 CONTACT INFORMATION..... VFR 10

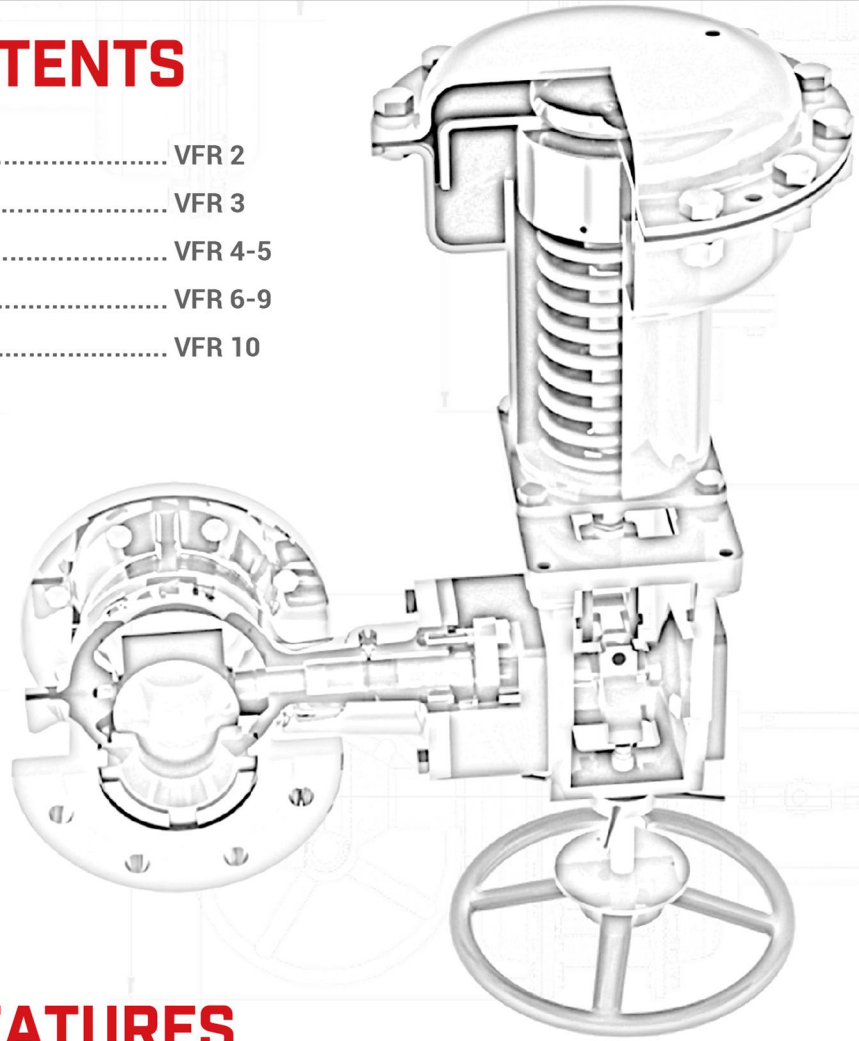

SERIES VFR FEATURES

- Offers the **High Control Performance** of a Globe Valve and Higher Cv
- **High Rangeability** of 100:1
- Plug with **Stabilizer Wing** Reduces Fluid Induced Torque and Turbulence to Provide Stable Operation
- **No Friction** between Plug and Seat Ensures Excellent Resolution and Controllability
- Rotary Action **Prevents Media** From Being Pulled through Packing
- **Minimum** Deadband and Hysteresis
- Space and **Cost Savings** Design
- Complies with **NACE MR0103/MR0175**
- Optional **Alloy Construction** and **Slurry Design** Available
- **Various Industries** including O&G, Chem/Petrochem, Desalination, Food and Beverage
- **Full Integral Bonnet** and Bolted Packing Box
- **Metal and Soft Seat Options** to Class IV and VI
- Retained Seat Ring with **Threaded Retainer**
- Keyway used for Plug/Stem Attachment for **Easy Replacement and Servicing**

ROTARY ECCENTRIC PLUG VALVE

KEY COMPONENTS

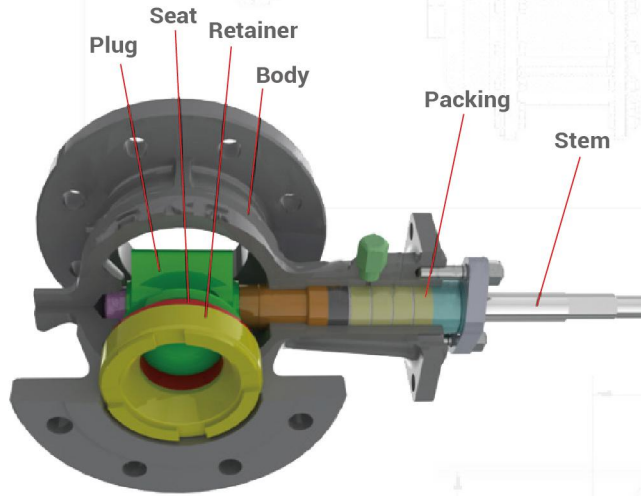

Type	Rotary Eccentric Plug Valve
Body Size	1"-12" (DN25-DN300) Wafer, 1"-14" (DN25-DN350) Flanged
Plug Characteristics	Eccentrically Rotating, Self Aligning, Modified Equal Percentage
Seat	Lock in Place
Pressure Classes	Class 150-600
Body Connections	RF Flanged, Wafer
Face to Face Dimensions	ANSI B16.5, RF Flanged

Name	Material
Bushing	316 SS/Stellite®, 304 SS/Stellite®, 440B-HT
Plug	17-4 PH, 304 SS, 316 SS, 304 SS/Stellite®, 316 SS/Stellite®, 316L, 304L
Seat	17-4 PH, 304 SS, 316 SS, 304 SS/Stellite®, 316 SS/Stellite®, 316L, 304L, PTFE
Retainer	17-4 PH, 304 SS, 316 SS, 304 SS/Stellite®, 316 SS/Stellite®, 316L, 304L
Body	LCC, CF8M, CF8, CF3M, CF3
Guide	304 SS/Stellite®, 316 SS/Stellite®
Packing	PTFE 8000-PHB, Graphite
Stem	17-4 pH, 304 SS, 316 SS, 304L, 316L

NOTES:

- 1) Rangeability is 100:1
- 2) Seat Leakage
 - a. Metal seat within 0.01% Cv to ANSI/FCI 70-2 Class IV
 - b. Soft seat to ANSI/FCI 70-2 Class VI
- 3) For flashing or cavitating service, Hardfaced 316 SS or Stellite trim is recommended
- 4) Soft seat pressure drops are limited by temperature
- 5) Optional materials are available; consult the factory
- 6) Pressure boundary parts are provided to ASTM standards
- 7) Valve internal materials are supplied to ASTM/JIS/DIN/GB equivalent
- 8) Compliance to NACE is available to MR0103 or MR01-75/ISO 15156

FLOW CHARACTERISTICS

CV VS STROKE CURVE

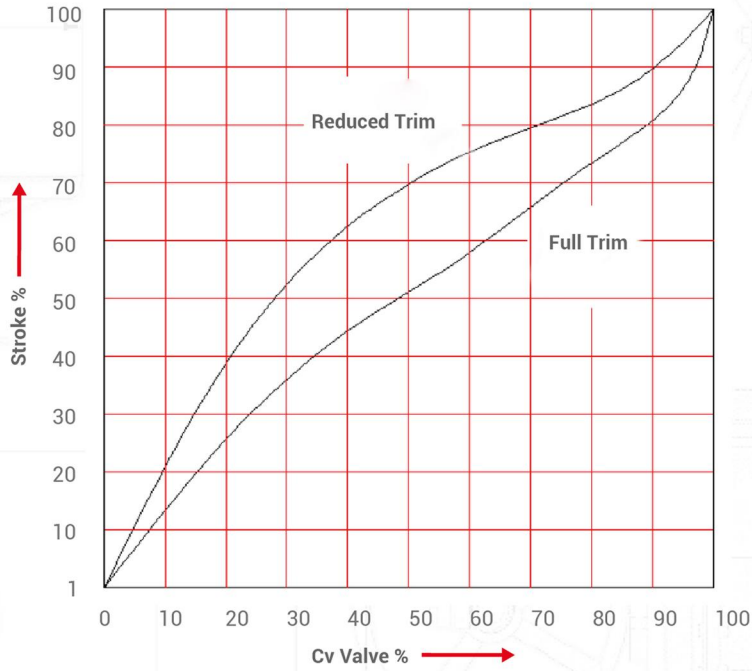

TRIM/MATERIAL VS PRESSURE/TEMPERATURE RATINGS

Pressure/Temperature Recommendation for Stellite

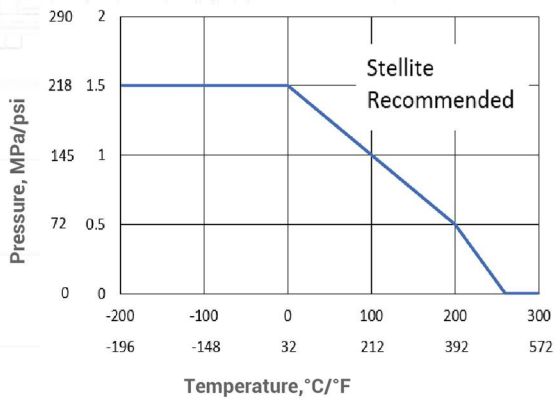

Pressure/Temperature Soft Seat Limits

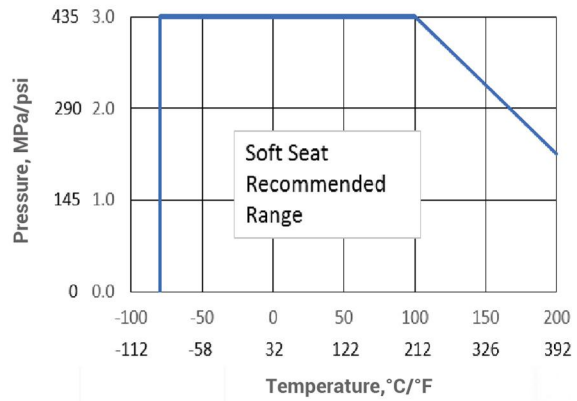

FLOW CHARACTERISTICS

RATED Cv FOR VALVE SIZES 1" (DN25) TO 12" (DN300)

Table 1: Rated Cv

Body Size		1" (DN25)	1 1/2" (DN40)	2" (DN50)	3" (DN80)	4" (DN100)	6" (DN150)	8" (DN200)	10" (DN250)	12" (DN300)	14" (DN350)
Cv	Cv Full Trim	14	30	50	150	250	600	1000	1400	1900	2600
	40% Cv	5.6	12	20	60	100	240	400	560	760	1040
	60% Cv	8.4	18	30	90	150	360	600	840	1140	1560

TYPICAL VALUES OF VALVE STYLE MODIFIER F_d , LIQUID PRESSURE RECOVERY FACTOR F_L , AND PRESSURE DIFFERENTIAL RATIO FACTOR X_T AT FULL RATED TRAVEL

Table 2: Valve Sizing Indices

Valve Type	Trim Type	Flow Direction	F_L	X_T	F_d	K_c
Rotary	Eccentric Spherical Plug	Open	0.85	0.61	0.42	0.60
		Close	0.68	0.40	0.42	0.35

NOTES:

1) Flow tends to open or close the valve, i.e. push the closure device (plug, ball, or disc) away from or towards the seat.

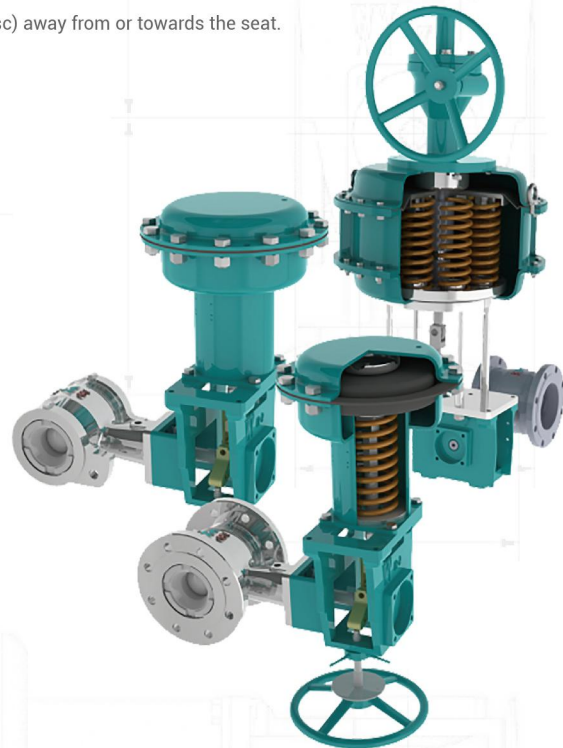

DIMENSIONS & WEIGHTS

Table 3.1: Wafer Body Outline Dimensions Metric and Fig. 3.1 and 3.2

Valve Size inch/(mm)	Body Rating	Actuator	K mm	A mm	B mm	P mm	H mm	L mm	M mm	weight(kg)
1" (25)	Class150, Class 300	VR1	102	195	40	208	220	130	128	15
1.5" (40)	Class150, Class 300	VR1	114	201	45	208	220	130	128	16
2" (50)	Class150, Class 300, Class 600	VR1	124	205	49	218	220	130	128	17
3" (80)	Class150, Class 300, Class 600	VR2	165	310	65	315	420	220	220	55
4" (100)	Class150, Class 300, Class 600	VR2	194	315	110	315	420	270	200	66
6" (150)	Class150, Class 300, Class 600	VR3	229	420	150	315	585(505)	330	360	100
		MF5D-V	229	420	150	630	1384	107	355	190
8" (200)	Class150, Class 300, Class 600	VR3	243	449	180	315	585(500)	330	360	125
		MF5D-V	243	449	180	630	1384	132	355	215
10" (250)	Class150, Class 300	VR3	297	510	220	315	575(495)	335	360	165
		MF5D-V	297	510	220	630	1384	162	355	260
12" (300)	Class150, Class 300	VR3	338	530	260	315	570	340	360	180
		MF5D-V	338	530	260	630	1384	185	355	280

NOTES:

Face dimensions of (H) when the spring of 0.08-0.16Mpa.

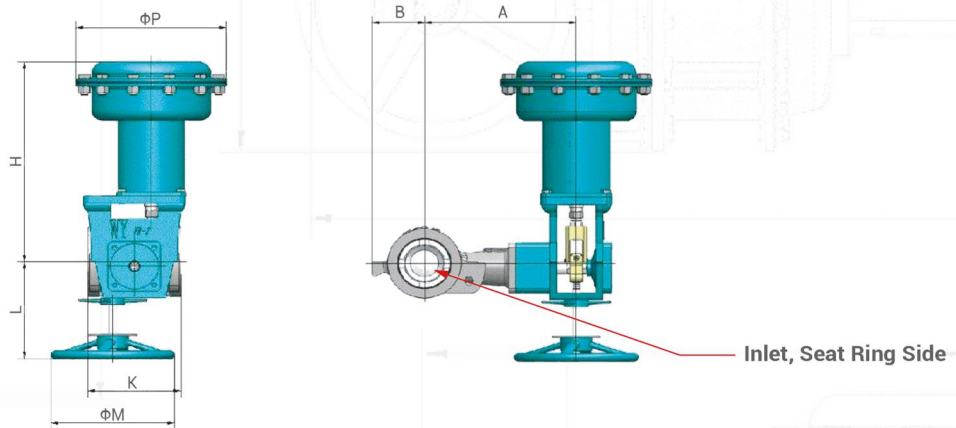

Fig. 3.1: Wafer Bodies With VR Actuator

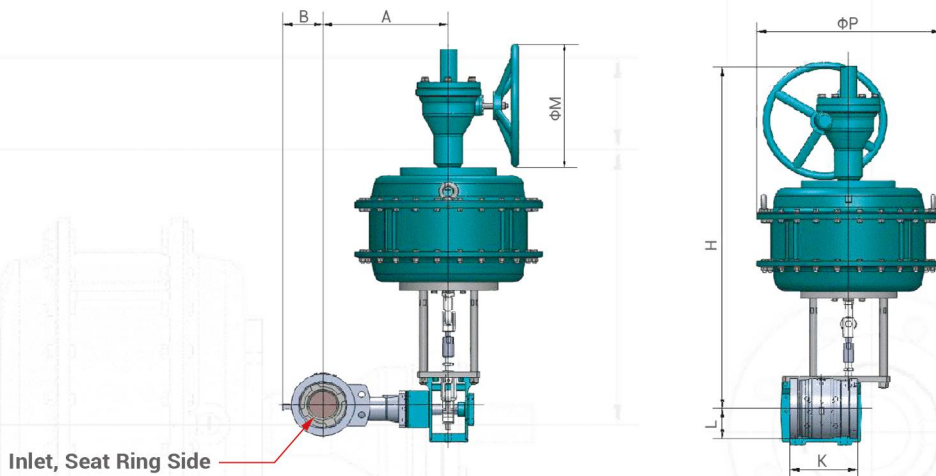

Fig. 3.2: Wafer Bodies With MF5D-V Actuator

DIMENSIONS & WEIGHTS

Table 3.2: Wafer Body Outline Dimensions Metric and Fig. 3.1 and 3.2

Valve Size inch/(mm)	Body Rating	Actuator	K inch	A inch	B inch	P inch	H inch	L inch	M inch	weight(lb)
1" (25)	Class150, Class 300	VR1	4.0	7.68	1.6	8.2	8.7	5.1	5.0	33
1.5" (40)	Class150, Class 300	VR1	4.5	7.91	1.8	8.2	8.7	5.1	5.0	35
2" (50)	Class150, Class 300, Class 600	VR1	4.9	8.07	1.9	8.6	8.7	5.1	5.0	37
3" (80)	Class150, Class 300, Class 600	VR2	6.5	12.20	2.6	12.4	16.5	8.7	8.7	121
4" (100)	Class150, Class 300, Class 600	VR2	7.6	12.4	4.3	12.4	16.5	10.6	7.9	145
6" (150)	Class150, Class 300, Class 600	VR3	9.0	16.54	5.9	12.4	23.0(19.9)	13.0	14.2	220
		MF5D-V	9.0	16.54	5.9	24.8	54.5	4.2	14.0	418
8" (200)	Class150, Class 300, Class 600	VR3	9.6	17.68	7.1	12.4	23.0(19.9)	13.0	14.2	275
		MF5D-V	9.6	17.68	7.1	24.8	54.4	5.2	14.0	473
10" (250)	Class150, Class 300	VR3	11.7	20.08	8.7	12.4	22.6(19.5)	14.0	14.2	363
		MF5D-V	11.7	20.08	8.7	24.8	54.5	14.2	14.0	572
12" (300)	Class150, Class 300	VR3	13.3	20.87	10.2	12.4	22.4	13.4	14.2	396
		MF5D-V	13.3	20.87	10.2	24.8	54.5	7.3	14.2	616

NOTES:

Face dimensions of (H) when the spring of 0.08-0.16Mpa.

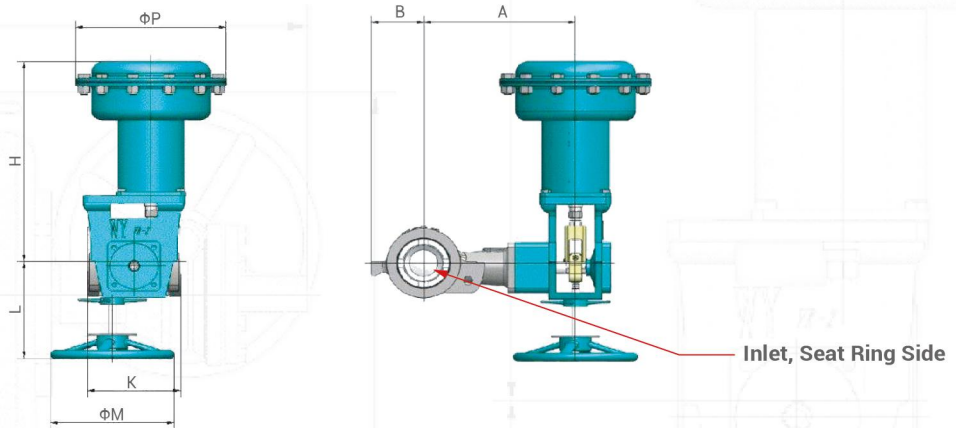

Fig. 3.1: Wafer Bodies With VR Actuator

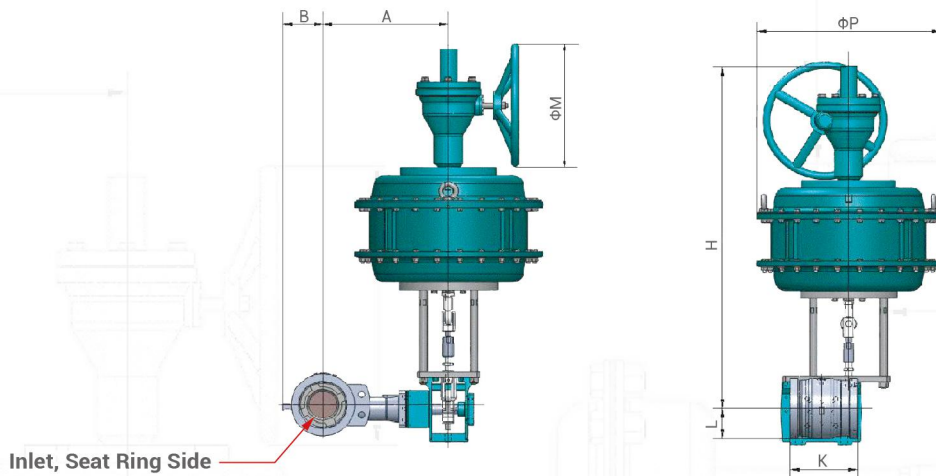

Fig. 3.2: Wafer Bodies With MF5D-V Actuator

DIMENSIONS & WEIGHTS

Table 3.3: Flange Body Outline Dimensions Metric and Fig. 3.3 and 3.4

Valve Size inch/(mm)	Body Rating	Actuator	K mm	A mm	B mm	P mm	H mm	L mm	M mm	weight(kg)
1" (25)	Class150, Class 300	VR1	127	195	70	208	220	130	128	16
1.5" (40)	Class150, Class 300	VR1	165	201	85	208	220	130	128	18
2" (50)	Class150, Class 300, Class 600	VR1	165	205	90	218	220	130	128	20
3" (80)	Class150, Class 300	VR2	194	310	108	315	420	220	220	60
	Class 600	VR2	229	310	108	315	420	220	220	60
4" (100)	Class150, Class 300	VR2	194	315	138	315	420	270	200	73
	Class 600	VR2	229	315	138	315	420	270	200	73
6" (150)	Class150, Class 300	VR3	229	420	173	315	585(505)	330	360	110
		MF5D-V	229	420	173	630	1384	173	355	200
	Class 600	VR3	267	420	173	315	585(505)	330	360	110
		MF5D-V	267	420	173	630	1384	173	355	200
8" (200)	Class150, Class 300, Class 600	VR3	297	449	210	315	585(500)	330	360	140
		MF5D-V	297	449	210	630	1384	208	355	230
10" (250)	Class150, Class 300	VR3	330	510	225	315	575(495)	335	360	187
		MF5D-V	330	510	225	630	1384	225	355	282
12" (300)	Class150, Class 300	VR3	338	530	260	315	570(490)	340	360	212
		MF5D-V	338	530	260	630	1384	260	355	310
14" (350)	Class150, Class 300, Class 600	MF5D-V	535	571	260	630	1384	291	355	360

NOTES:

Face dimensions of (H) when the spring of 0.08-0.16Mpa.

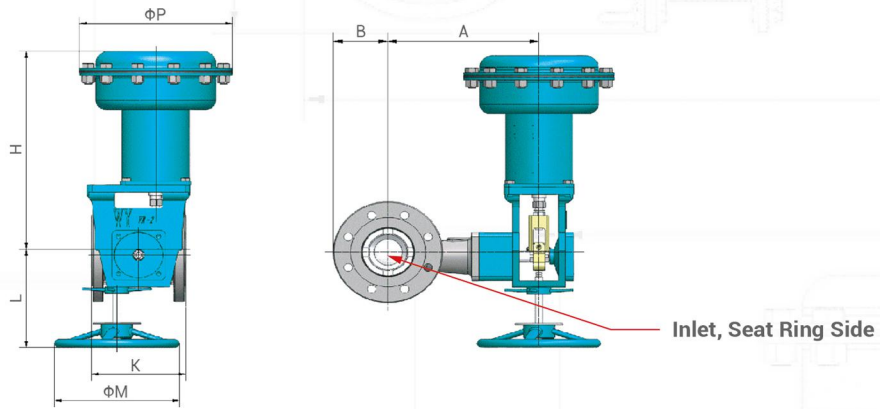

Fig. 3.3: Flange Bodies With VR Actuator

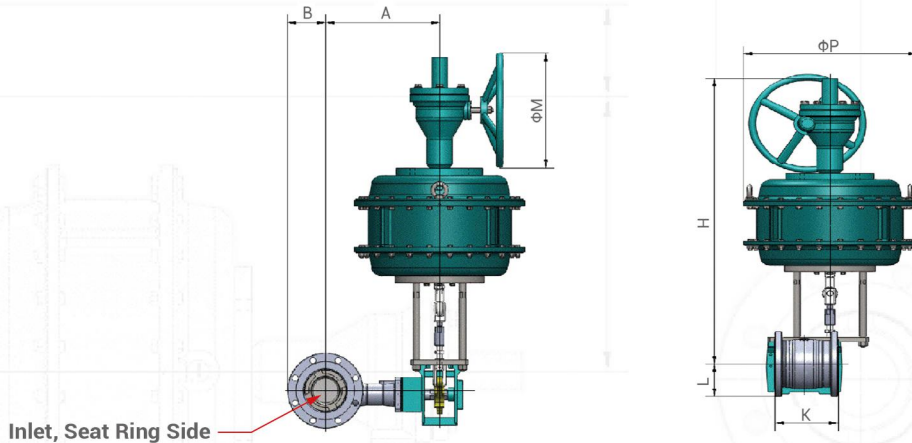

Fig. 3.4: Flange Bodies With MF5D-V Actuator

DIMENSIONS & WEIGHTS

Table 3.4: Flange Body Outline Dimensions Metric and Fig. 3.3 and 3.4

Valve Size inch/(mm)	Body Rating	Actuator	K inch	A inch	B inch	P inch	H inch	L inch	M inch	weight(lb)
1" (25)	Class150, Class 300	VR1	5.00	7.7	2.8	8.2	8.7	5.1	5.0	35
1.5" (40)	Class150, Class 300	VR1	6.50	7.9	3.3	8.2	8.7	5.1	5.0	40
2" (50)	Class150, Class 300, Class 600	VR1	6.50	8.1	3.5	8.6	8.7	5.1	5.0	44
3" (80)	Class150, Class 300	VR2	7.64	12.2	4.3	12.4	16.5	8.7	8.7	132
	Class 600	VR2	9.02	12.2	4.3	12.4	16.5	8.7	8.7	132
4" (100)	Class150, Class 300	VR2	7.64	12.4	5.4	12.4	16.5	10.6	7.9	161
	Class 600	VR2	9.02	12.4	5.4	12.4	16.5	10.6	7.9	161
6" (150)	Class150, Class 300	VR3	9.02	16.5	6.8	12.4	23.0(505)	13.0	14.2	242
		MF5D-V	9.02	16.5	6.8	24.8	54.5	6.8	14.0	440
	Class 600	VR3	10.50	16.5	6.8	12.4	23.0(19.9)	13.0	14.2	242
		MF5D-V	10.50	16.5	6.8	24.8	54.5	6.8	14.0	440
8" (200)	Class150, Class 300, Class 600	VR3	11.69	17.7	8.3	12.4	23.0(19.7)	13.0	14.2	308
		MF5D-V	11.69	17.7	8.3	24.8	54.5	8.2	14.0	506
10" (250)	Class150, Class 300	VR3	13.00	20.1	8.9	12.4	22.6(19.5)	13.2	14.2	411
		MF5D-V	13.00	20.1	8.9	24.8	54.5	8.9	14.0	620
12" (300)	Class150, Class 300	VR3	13.31	20.9	10.2	12.4	22.4(19.3)	13.4	14.2	466
		MF5D-V	13.31	20.9	10.6	24.8	54.5	10.2	14.0	682
14" (350)	Class150, Class 300, Class 600	MF5D-V	21.06	22.5	10.2	24.8	54.5	11.5	14.0	792

NOTES:

Face dimensions of (H) when the spring of 0.08-0.16Mpa.

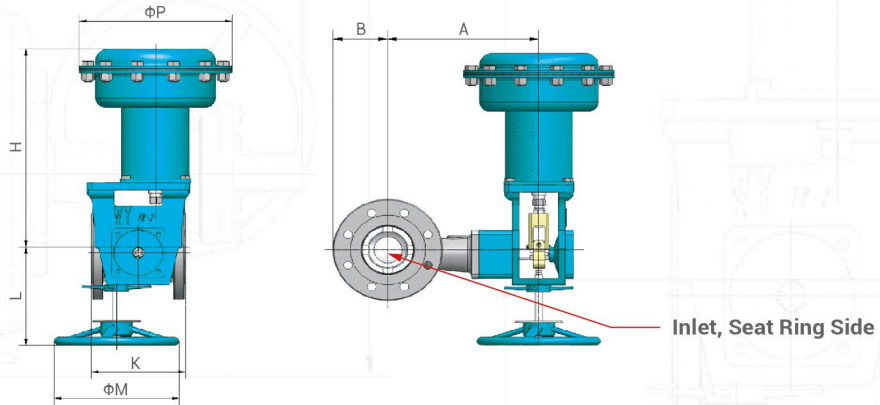

Fig. 3.3: Flange Bodies With VR Actuator

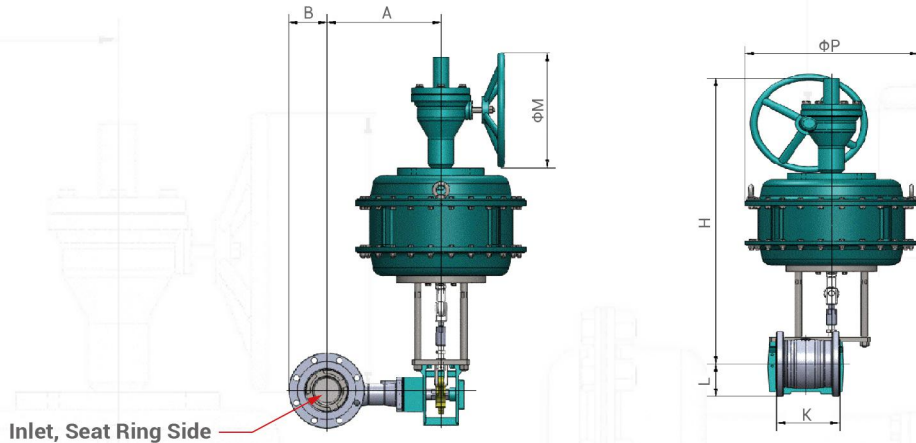

Fig. 3.4: Flange Bodies With MF5D-V Actuator

WHO WE ARE

WZI Flow Control, Ltd., a subsidiary of WuZhong Instrument Company, Ltd., began business in 1959. As China's largest control valve manufacturer, WZI has a state of the art 2.8M ft² production, foundry and corporate office campus. With over 1000 employees, WZI is expanding globally with increased manufacturing, sales and service capabilities to better serve our rapidly growing global customer base.

As a member of the highly acclaimed China Automation Group (www.cag.com.hk), WZI has successfully supplied over 1 million valves for the global market. With our 100% Testing and Serialization Program, WZI prides itself on our high quality, competitively priced products with superior delivery from our new sales and service center located in Houston, Texas. Our Southern California office designs new products and makes continuous improvements to our broad existing product offering.

LET'S WORK TOGETHER

Contact US

 +1.832.328.7883

 Sales@WZIFlowControl.com

Location

USA Headquarters

5656 N. Sam Houston Pkwy E., Suite 150
Houston, Texas 77032 USA

www.WZIFlowControl.com

WE'RE QUALIFIED

As a global manufacturing company, WZI Flow Control verifies that we are operating in full compliance with this partial list of industry standards. Our compliance includes additional standards not shown here. Please contact the factory for additional details.

> ISO 9001
> ISO 14001
> OHSAS 18001

> API Spec Q1
> API 6A
> API 6D

> API 6DSS
> API 17D
> API 609 Cat B

> API 607, 7th Edition
> API 6FA, 3rd Edition
> SIL-capable

QUALITY
TRUST
INTEGRITY

Disclaimer: The information and specifications contained in this literature are believed to be accurate, they are supplied for information purposes and should not be considered certified or a guaranty of satisfactory results by reliance thereon. Nothing contained in this literature is to be construed as a warranty or guaranty, express or implied. Because WZI Flow Control is continually improving our product, the specifications, dimensions, and information contained in this literature are subject to change without notice. Should any questions arise concerning these provisions, the purchaser or user should contact WZI Flow Control at the contact information given.

© 2019 WZI Flow Control, LTD. All rights reserved.

PB_VFR_1219