

WZI FLOW CONTROL



QUALITY | TRUST | INTEGRITY

📍 5656 North Sam Houston Parkway East, Suite 150 | Houston, TX. 77032, USA | ☎️ 832.328.7883

www.WZIFlowControl.com



The WZI Flow Control Story

WZI Flow Control, Ltd., a subsidiary of WuZhong Instrument Company, Ltd., began business in 1959. As China's largest control valve manufacturer, WZI has a state of the art 2.8M sq/ft production, foundry and corporate office campus. With over 1000 employees, WZI is expanding globally with increased manufacturing, sales and service capabilities to better serve our rapidly growing global customer base.

As a member of the highly acclaimed China Automation Group (www.cag.com.hk), and publicly listed on the Hong

Kong Stock Exchange, WZI has successfully supplied over 1 million valves for the global market. Our 100% Testing and Serialization Program, WZI prides itself on our high quality, competitively priced products with superior delivery from our new sales and service center located in Houston, Texas. Our Southern California office designs new products and makes continuous improvements to our broad existing product offering.



OUR PRODUCTS

CONVENTIONAL CONTROL VALVES 4

- > Top Guided Globe
- > Cage Guided Globe
- > Quick Change Trim
- > Single/Multistage/Low Noise
- > Balanced/Unbalanced

CONTROL VALVES 5

- > Multistage Designs
- > Limited Pressure Drop Staging
- > Controls Noise and Cavitation
- > Pre-Engineered and Built to Order
- > Patented Technology

ROTARY CONTROL VALVES 6

- > Eccentric Plug Valve
- > V-Ball
- > Triple Offset Control
- > Soft and Metal Seats
- > High Rangeability

BALL VALVES 7

- > Floating
- > Trunnion
- > Metal Seated
- > Teflon Lined
- > Steam Jacketed

BUTTERFLY VALVES 8

- > Fabricated Dampers
- > High Performance
- > Triple Offset
- > Fully Teflon Lined
- > Soft and Metal Seats

SPECIALTY VALVES 9

- > Angle and Globe
- > Rotary and Linear Drive Axial Flow
- > Tank Drain
- > High Pressure/High Temperature

CONTROL ACCESSORIES 10

- > Spring Diaphragm
- > Double Acting Pneumatic Cylinders
- > Rack and Pinion
- > Scotch Yoke
- > Electric
- > Solenoid, Limit Switches, Positioner

ENGINEERING, SUPPORT AND TESTING SERVICES 11

- > R&D Facility
- > Cryogenic and High Pressure Gas Testing
- > Service and Repair of WZI Products
- > Service and Repair of **ALL** Competitors' Control Valves
- > Foundry for OEM Parts and Private Label Agreements



CONVENTIONAL CONTROL VALVES

The WZI Series A Control Valve covers a wide range of sizes, pressure classes, temperature ranges, and trim configurations. Trim configurations will vary from top guided plug orifice, cage guided drilled hole designs, single/multiple stages, with unbalanced and balanced trims. All trims offer quick change capabilities for simplified and timely servicing allowing for less down time. Three way designs can also be supplied in many

of the sizes. Sizes range from 1/2" through 28", with pressure classes of 150# through 1500#. The valve can be supplied in a variety of materials and bonnet extensions for service temperatures from minus -320°F to 1100°F. Flanged and weld end connections are standard, and angle pattern configurations are also available. Valves can be supplied with WZI's MF series spring diaphragm actuators, VP or MP single and double acting pistons, or with customer specified actuators.

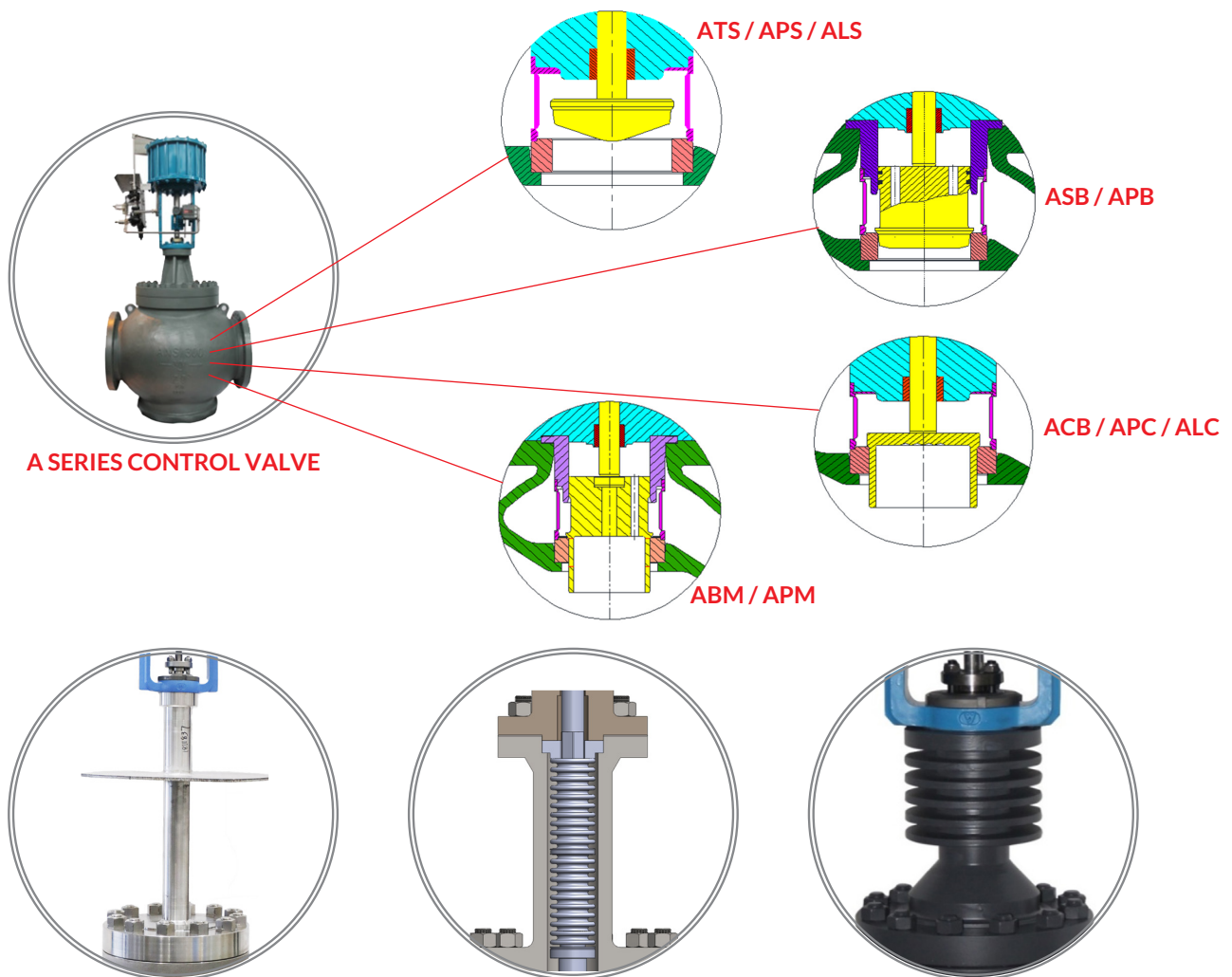

CRYOGENIC, BELLOWS, AND FINNED BONNET EXTENSIONS ARE OPTIONAL

SEVERE SERVICE CONTROL VALVES

WZI compliments its wide range of standard control valves with Engineered to Order and Pre-Engineered multistage product lines. These products are designed to handle services that would result in excessive noise, vibration or premature

failure in more conventional valves. These products can be supplied to conventional ASME Class, Interpolated Class, Job Rated or API 6A.

ATM AND ATE CONTROL VALVES

- Pressure Rating and Size Built to Order
- Leakage FCI-70 Class IV, V, VI, MSS-SP61
- Temperature -320°F to 1100°F

The ATE is a WZI patented technology and has been produced since 2010. Drilled holes and milled slots in the throttle elements form a tortuous flow path and are press fit and welded into a cage. The cage can be characterized depending on service.

The ATM control valve utilizes proven multistage/multipath technology and can be provided with linear or modified percent trim. The product has been produced since 2014 at WZI. These valves have been supplied for high pressure steam services, boiler feed pump recycle, feedwater regulator, spray water control, compressor recycle, High Temperature High Pressure Separator Level Control, and a variety of other applications. The ATM and ATE Control Valves are engineered to meet specification requirements and provide long service life. These valves can be supplied to various levels of noise, cavitation, and discharge energy control.

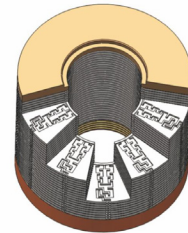
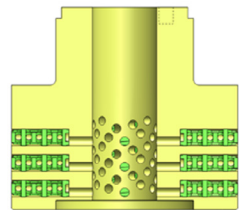
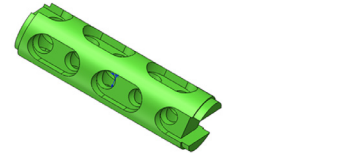

ATL CONTROL VALVES

- Sizes 1" through 4"
- Pressure Rating 300# to 2500# Class ATM Cage
- Leakage FCI-70 Class IV, V, MSS-SP61
- Temperature -50oF to 1100oF

The ATL Control Valve has been produced since 2017 at WZI. The multistage axial flow notch style trim provides improvement on current industry designs, with linear and modified percentage characterized trim for better control based on the application. The application of the product uses both limits on pressure drop per stage and cavitation prevention, providing superior performance and meeting very low trim discharge energies. The ATL is similar to WZI's HTN/HTC series, which WZI has extensive experience. The ATL has been designed for ease of servicing in the field. The product is available as a standard product with NACE options, or can be custom designed for extended size ranges and temperature.

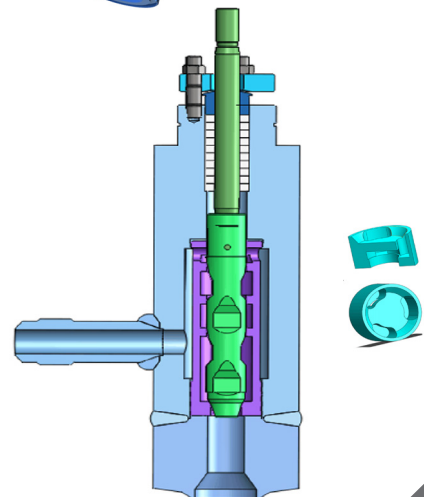
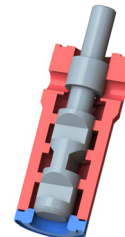

HTC/HTN CONTROL VALVES

- Sizes 1" through 4"
- Pressure Rating 600# to 2500# Class
- Leakage FCI-70 Class IV, V
- Temperature -50oF to 1050oF

The HT series control valve has been produced since 2010 at WZI. Flow throttles through the notches in the plug with guide rings in the liner separating stages to provide a tortuous flow path. Various configurations of the product can be used as a throttling 4 to 6 stage letdown, and can be combined with additional stages of fixed restrictions downstream. The notches are designed to provide a modified percentage characteristic for better control. The product has been successfully applied in fossil power as well as petrochemical high pressure drop applications.

ROTARY CONTROL VALVES

VFR ECCENTRIC PLUG VALVE

- Size 2" through 18"
- Pressure Rating 150# to 900# Class
- Rotation 90°
- Leakage FCI-70 Class IV and VI
- Temperature -75°F to 1050°F

The VFR is a rotary plug valve with an eccentric plug mounting that reduces rubbing action on the seat when opening or closing to improve service life. The plug is equipped with a flow wing for reduced torque and better stability in operation. Full or reduced capacity trims are standard, with 300SS trim, hardened stainless steels, and high temperature trim options. For erosive or slurry services, special tungsten carbide or ceramic trim options are available.

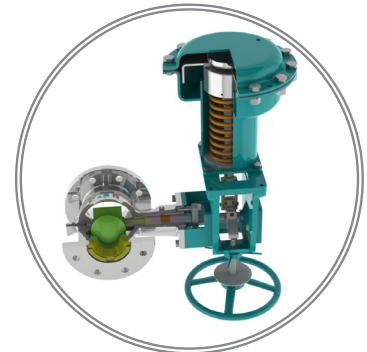

VFR ECCENTRIC PLUG VALVE

V2100 V-BALL

- Size 1" through 20"
- Pressure Rating 150# to 300# Class
- Rotation 90°
- Leakage FCI-70 Class IV, V, or VI
- Temperature -20°F to 985°F

The V2100 V-Ball is a segmented ball with a shaped V notch on the ball for an equal percentage characteristic and high rangeability control. The V shaped notch and seal provides a positive shearing action for services with fibers in suspension. A variety of trim options varying from soft seat, hardened trim, or high temperature materials are available.

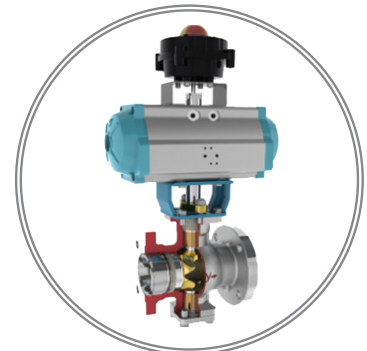

V2100 V-BALL



BALL VALVES

WZI supplies a variety of full port 2 and 3 piece ball valve products for on/off or throttling services. Special custom designs can also be produced. Seat leakage ratings meet API 598 and GB/T13927 and can be certified to API 607 for soft seats and API 607FA for hard seats. Balls and

seats can be nitrided, HVOF coated with a tungsten or chrome carbides, nickel alloy spray and fuse, or stellite coated. WZI is certified to API 6A, API 6D, API 6DSS, API 17D and many additional standards.

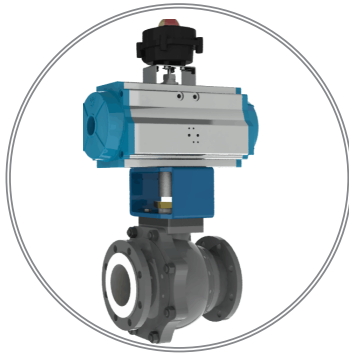

G1520

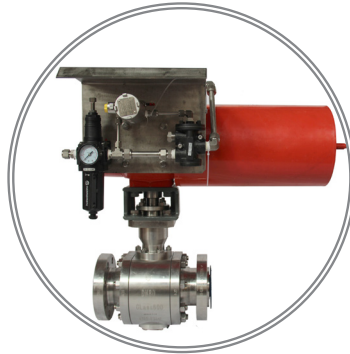

SPECIAL FORGED BALL



G3010

SERIES	SIZE	SEATING	PRESSURE CLASS
G1520	1/2" - 24"	Metal to Metal	150# to 600#
G2010	2" - 24"	Soft Seat	150# - 400#
G2030	1/2" - 8"	Metal to Metal or Soft Seat	150# - 400#
G2070	1/2" - 12"	Soft Seat	150# - 400#
G3010	1" - 18"	Soft Seat 1" - 10" Hard Seat 1"-18"	600# - 1500# to 16" 600# - 900# to 18"
G4100	1/2" to 6" Soft	Soft Seat	150# Teflon Lined
G6000	1/2" to 14"	Soft Seat Hard Seat	150# - 300#, Steam Jacketed

BUTTERFLY VALVES

WZI manufactures a wide range of butterfly products. Typical products and size ranges are shown. Materials available vary from carbon steels, chrome-moly alloys, to duplex and 300

series stainless steels. Standard rack and pinion actuators are available or customer specified actuators can be supplied.

WB100 BUTTERFLY FABRICATED FROM WELDED PLATE

- Size 8" through 104"
- Pressure Rating 150# Class
- Rotation 60° or 90° Leakage Swing through, 1% to 3% of Cv
- Mechanical Stop 0.2% to 0.8% of Cv

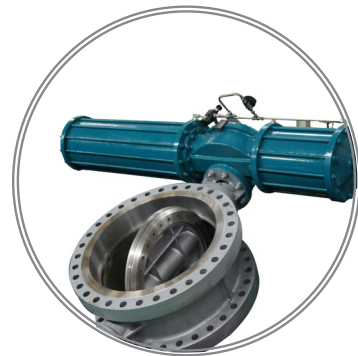

WB100

WB310 TRIPLE OFFSET BUTTERFLY

- Size 3" through 88"
- Pressure Rating 150# and 300# Class
- Rotation 60° or 90°
- Leakage API 598 for 304 SS / Graphite Seal
- FCI 70 Class V for full Stainless Steel.
- Temperature -50°F to 932°F

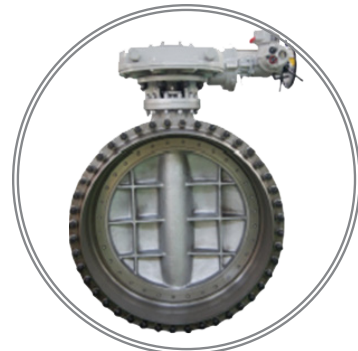

WB310

WB300 HIGH PERFORMANCE BUTTERFLY

- Size 2" through 32"
- Pressure Rating 150# Class Rotation
- 60° or 90°
- Leakage FCI-70 Class VI soft seat
- 0.00001% of Cv, metal seat
- Temperature -320°F to 932°F



WB300

WB410 TEFLON LINED BUTTERFLY

- Size 1.5" through 24"
- Pressure Rating 150# Class
- Rotation 60° or 90°
- Leakage API 598
- Temperature -20°F to 300°F



WB410

SPECIALTY VALVES

WZI is a specialty provider to various industries. In the downstream market, valves are supplied for services such as separator level control or in tank drain service which can see significant issues with solids, corrosion, and multi-phase flow. Midstream involves gas pipeline and transportation, and upstream can also involve high pressure drop service. The products shown below are only a partial listing of the products WZI manufactures.



ACV

ACV Angle valves are custom built pressure reducing angle valves provided with hardened and/or tungsten carbide materials. The valves can be equipped with an outlet venturi tube, multiple stage orifices, throttling axial flow notch trim, or a combination depending if the service is flashing or cavitating.



A2000 VALVES

The A2000 valves are a line of in-line axial flow valves typically provided in the midstream gas market. The streamlined body shape provides high capacity, and the valve can be fit with noise reducing trim as well. The valve has both linear and rotary drive actuation available based on size. Equipment up to 24" 900# has been supplied.

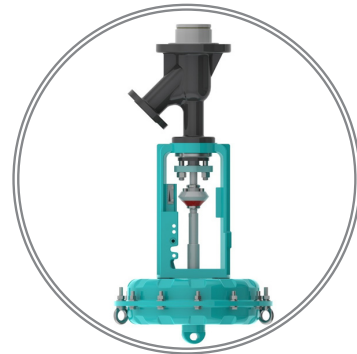

AYQ

The AYQ valves are designed for tank drain service. The high capacity Y pattern body allow rapid draining of the tank. Hardfaced seats for Class IV shutoff or soft seat for Class VI shutoff are available.

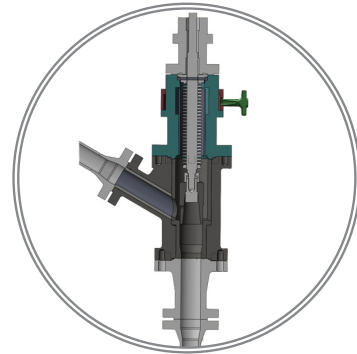

ACC

The ACC valve is designed for handling coal slurry or other high solids process streams. The valve can be provide with wear liners on the inlet and outlet. Conventional stem packing or bellows seal stem packing can also be provided.

ACTUATION AND CONTROL ACCESSORIES

The MF Series spring diaphragm actuator is a mainstay of WZI's actuators for reciprocating control valves. Utilizing multi-spring design, a high variation in spring ranges can be obtained. The actuator allowable operating pressure is 87 psi (6 bar), higher than most of what is current in the industry. Longer stroke is achieved on designs using a spacer between

diaphragm cases. The actuators are field reversible for spring failure action in most sizes. Side/top mounted handwheels, mechanical travel stops, low temperature diaphragm/seals, and a variety of control accessories are some of the options available.



ACTUATOR MODEL	MF2D/R	MF3D/R	MF4D/4	MF5D/R
AREA IN2	50	112	170	234
AREA CM2	320	720	1100	1510
MAXIMUM STROKE, INCH	1.18	2.36	2.95	4.72
MAXIMUM STROKE, MM	30	60	75	120

WZI manufactures two different cylinder actuator product lines; the VP series which is a double acting springless actuator and the MP series which is line of single and double acting spring return actuators. Both actuators are available with handwheels, low temperature seals, volume tanks, and fast acting control accessories. The air supply rating for the actuators is 7 bar (102 psi).



ACTUATOR MODEL	VP5	VP6	VP7	MP300	MP500	M2500	MP650	MP2650
AREA IN2	110	185	304	234	300	600	510	1020
AREA CM2	707	1195	1964	1510	1934	3868	3288	6577
MAXIMUM STROKE, INCH	1.97	3.94	3.94	4.72	7.87	5.9	7.87	6.3
MAXIMUM STROKE, MM	50	100	100	120	200	150	200	160



The AEP3000 is a smart electro-pneumatic single or double acting positioner provided for either rotary or linear valves. The positioner suitable for air supply of 20 to 100 psi. The positioner features standard linear, percentage, or customized response to a 4-20mA command signal including snap open/shut signal points. The positioner has a local LCD panel, auto-calibrates, is Hart compatible, has a 4-20 ma feedback, uses small amounts of air in steady state (0.1 SCFM @ 100 psi) and is highly vibration resistant. The positioner can be supplied with a hazardous area enclosure (IP66), with certifications to Eexd IIB-T6 or Exia IIC-T6. The positioner is rated for -22°F to 175°F operation.

ENGINEERING, SUPPORT AND TESTING SERVICES

WZI performs Engineering, Support, and Testing Services for its control and isolation valve lines, automation and control accessories. Our facility includes two large recessed bays for cryogenic and high pressure gas testing as well as anechoic chambers for acoustic testing of control valves. These facilities are also available for contract testing services. With a 200+ member service team, WZI provides global aftermarket support with in-house and in-field service personnel and mobile

machine shops. WZI's customer support includes servicing and maintenance of WZI's valves and all other valve manufacturers. Services include repair, replacement with OEM parts and review and re-engineering of troublesome valve applications in the field.

-
- R&D Facility Expanded
 - Cryogenic and High Pressure Gas Testing
 - Anechoic Chambers for Acoustic Testing
 - Fugitive Emission Testing
 - 42" Flow Loop
 - Flow Capacity Testing up to 42"
 - Available to Contract for Testing Services



-
- Complete service and repair of all WZI products
 - Complete service and repair of **ALL** competitors' control globe valves
 - Customer support includes repair, replacement with OEM parts, review and engineering of trouble valves



Damaged multistage valve trim with new replacement trim engineered and manufactured by WZI.



Redesigned plug assembly to resolve failure to open problem.

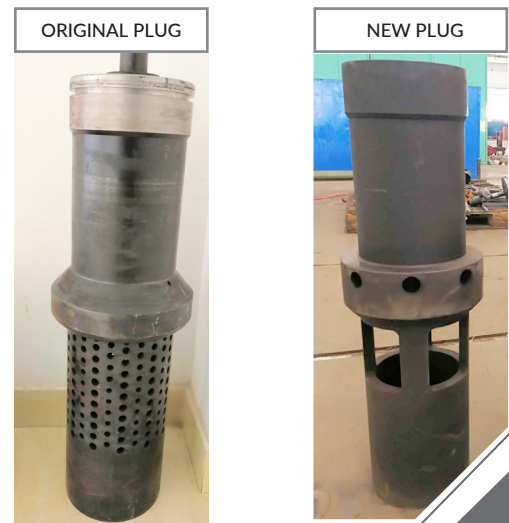

WZI FLOW CONTROL, LTD.

📍 5656 North Sam Houston Pkwy East,
Suite 150
Houston, TX 77032 USA
☎ Tel: 832.328.7883

✉ Sales@WZI FlowControl.com
✉ Engineering@WZI FlowControl.com

WZI FLOW CONTROL, LTD.

📍 999 Corporate Drive,
Suite 190
Ladera Ranch, CA 92694 USA
☎ Tel: 949.481.4434

OUR CERTIFICATES

As a global manufacturing company, WZI Flow Control verifies that we are operating in full compliance with this partial list of industry standards. Our compliance includes additional standards not shown here. Please contact the factory for additional details.



DISCLAIMER:

When properly selected, WZI products are designed to perform its intended function safely during its useful life. The purchaser or user of WZI products should be aware the products are used in numerous applications under a wide variety of service conditions. WZI can provide general guidelines but cannot provide specific data and warnings for all possible applications. The purchaser and or user assumes the ultimate responsibility for the proper sizing, selection, installation, maintenance, operation, training and safe use of WZI products. The information and specifications contained in this literature are believed to be accurate and supplied for informational purposes only. As WZI Flow Control, Ltd. is continually improving our products, the information contained in this literature is subject to change without notice.